

**Tree Planting Detail, 14-16cm girth, rb Scale 1:50**

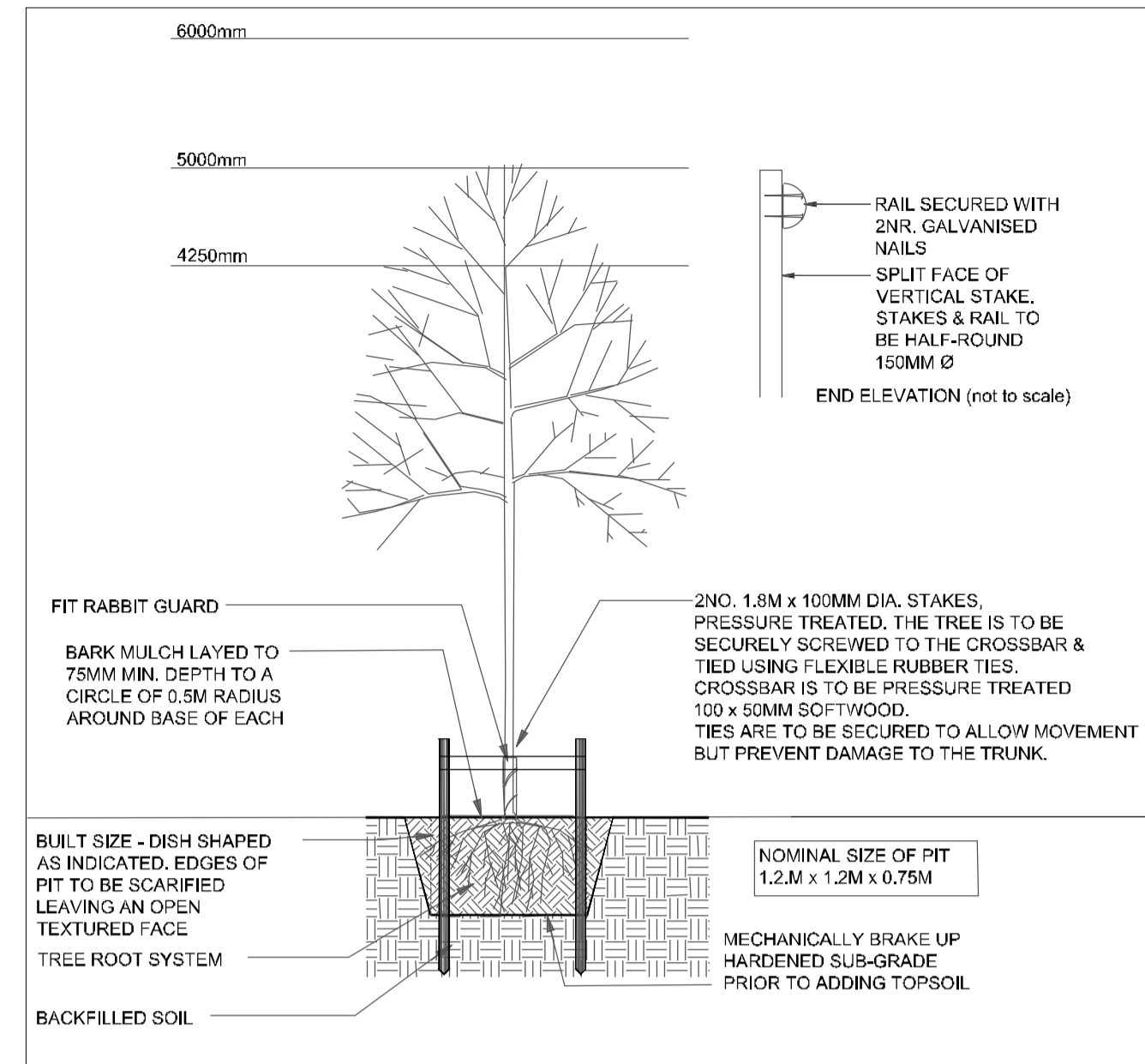

**Typical Double Tree Staking Detail Scale (1:25)**

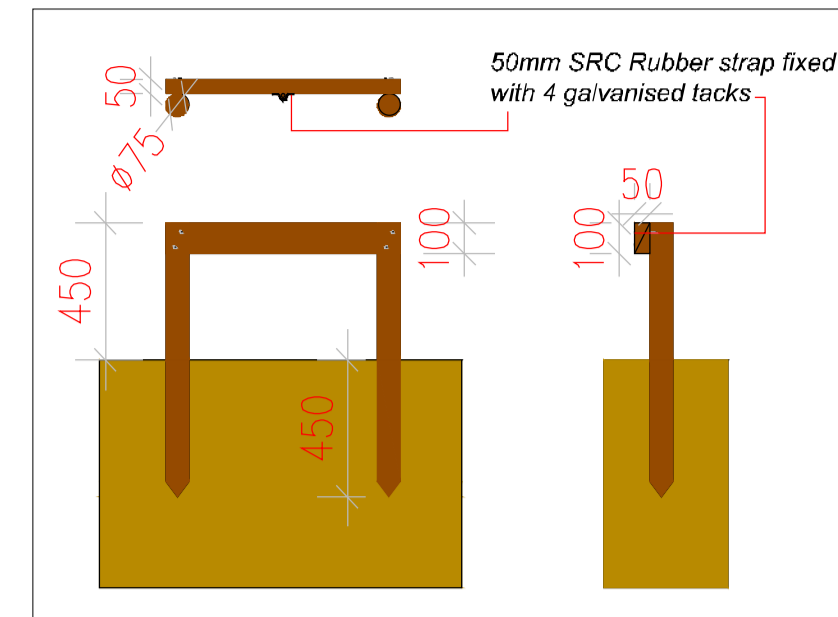

**Shrub Planting Detail**

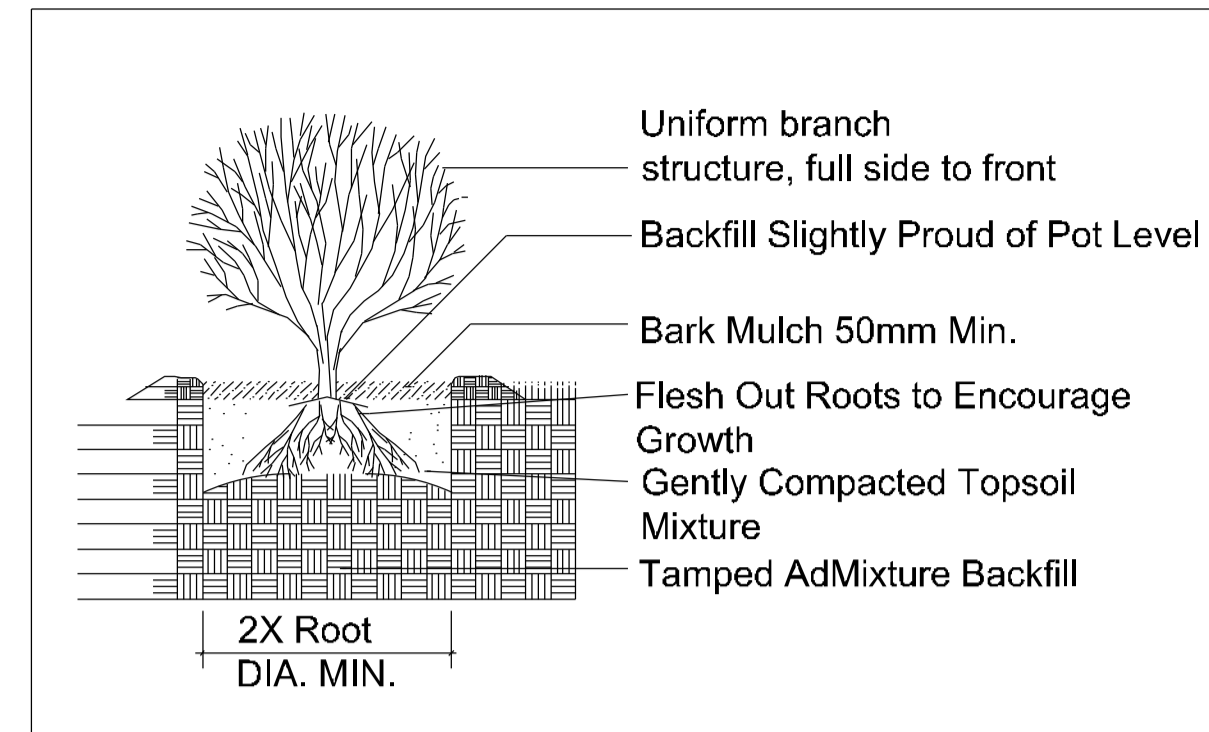

**Boundary Treatment - Scale (1:50)**

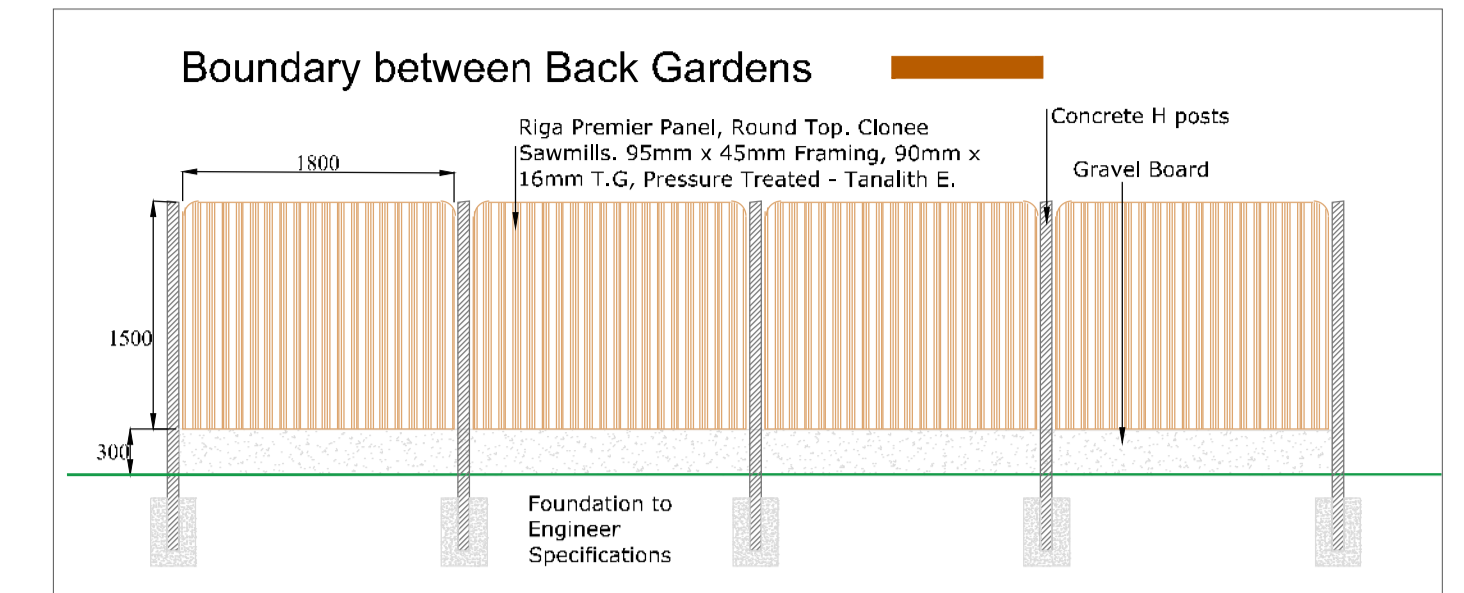

**Single Tree Staking Detail Scale (1:25)**

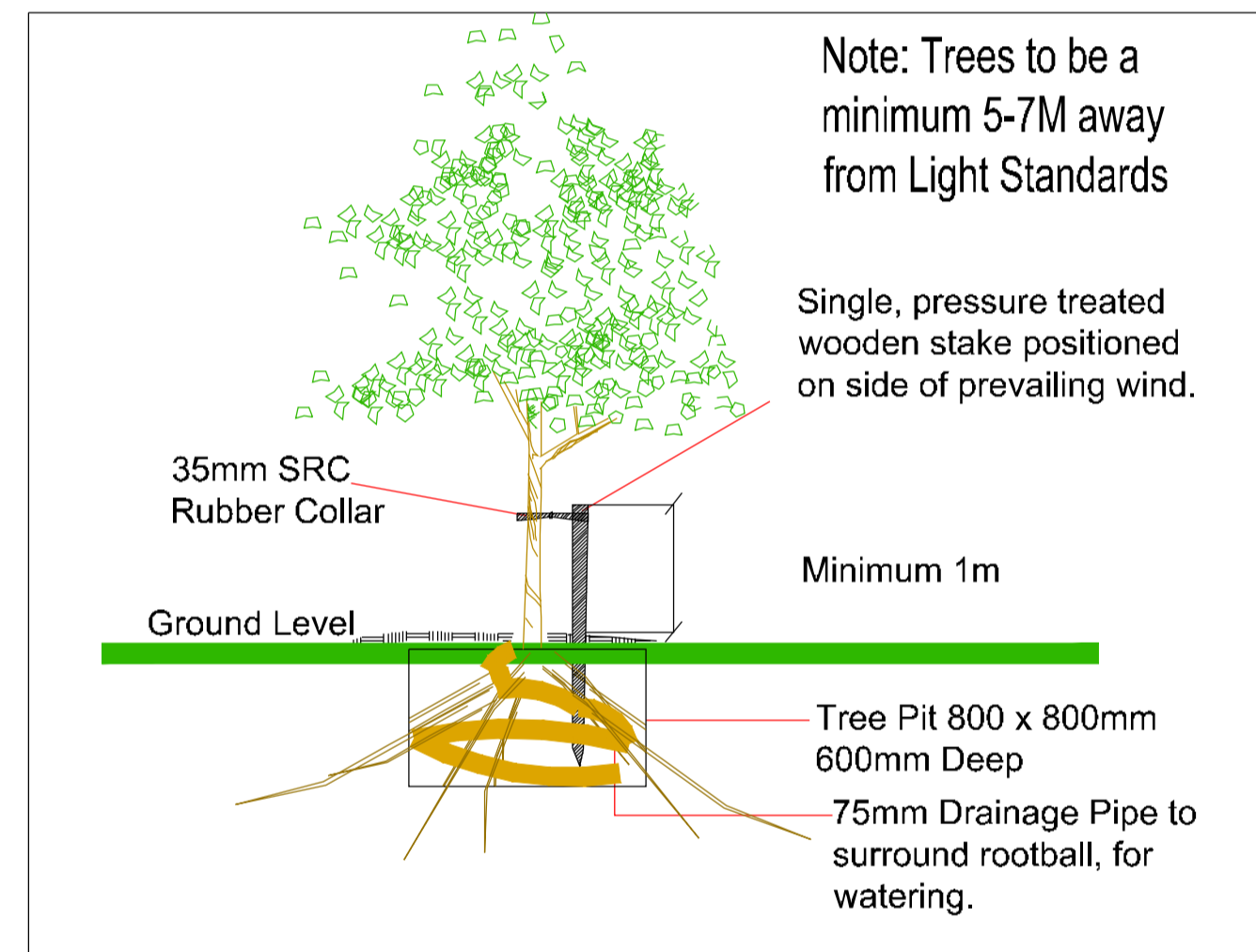

**Typical Detail of Gravel Drainage Against House Front - (Scale 1:5)**

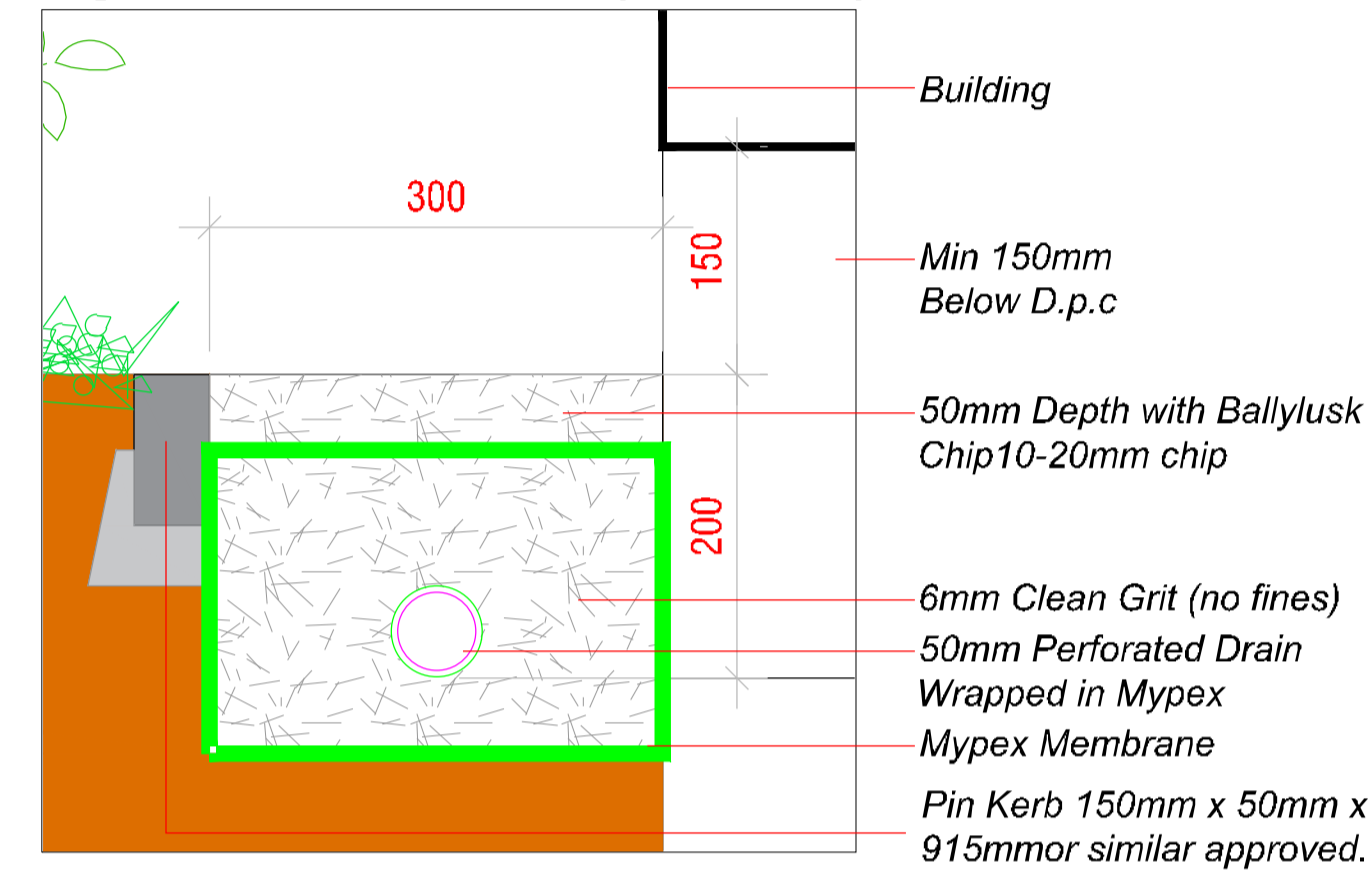

**H2 Proposed Native Hedgerow Planting Mix**

- Boundary detail - Hedge mix Whips, 60 - 90cm
- 50% Craetagus monogyna
  - 35% Prunus spinosa
  - 5% Ilex aquifolium
  - 5% Rosa canina
  - 5% Lonicera periclymenum 'Graham Thomas'
- 50 x 50 stake tied with a single rubber gut tie. 2 rows 400mm apart, 600mm centres

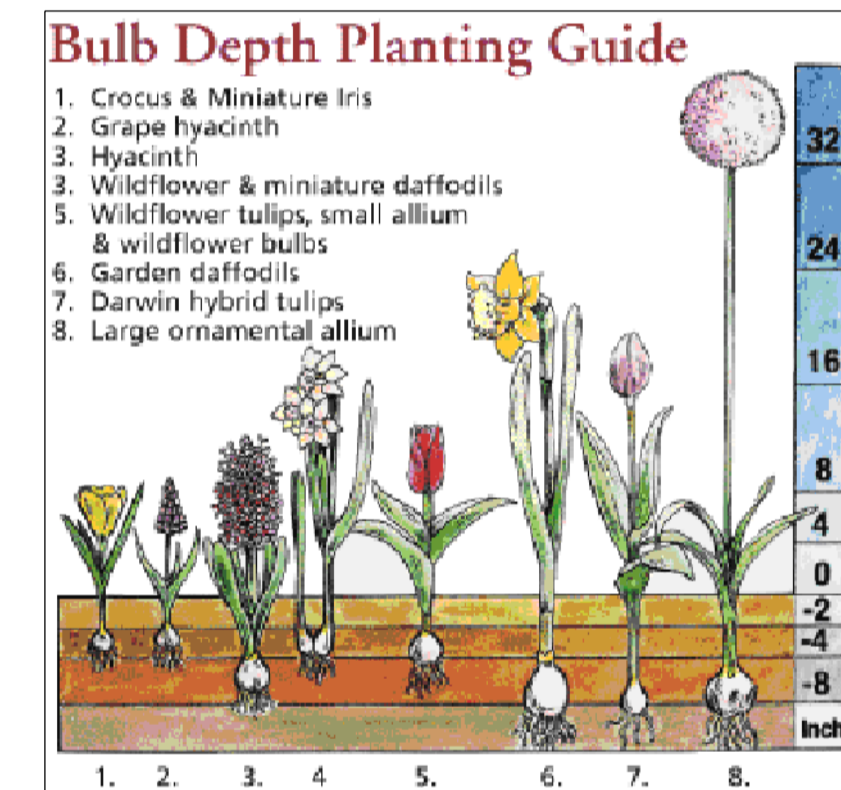

**Minimum Soil Depths (Scale 1:20)**

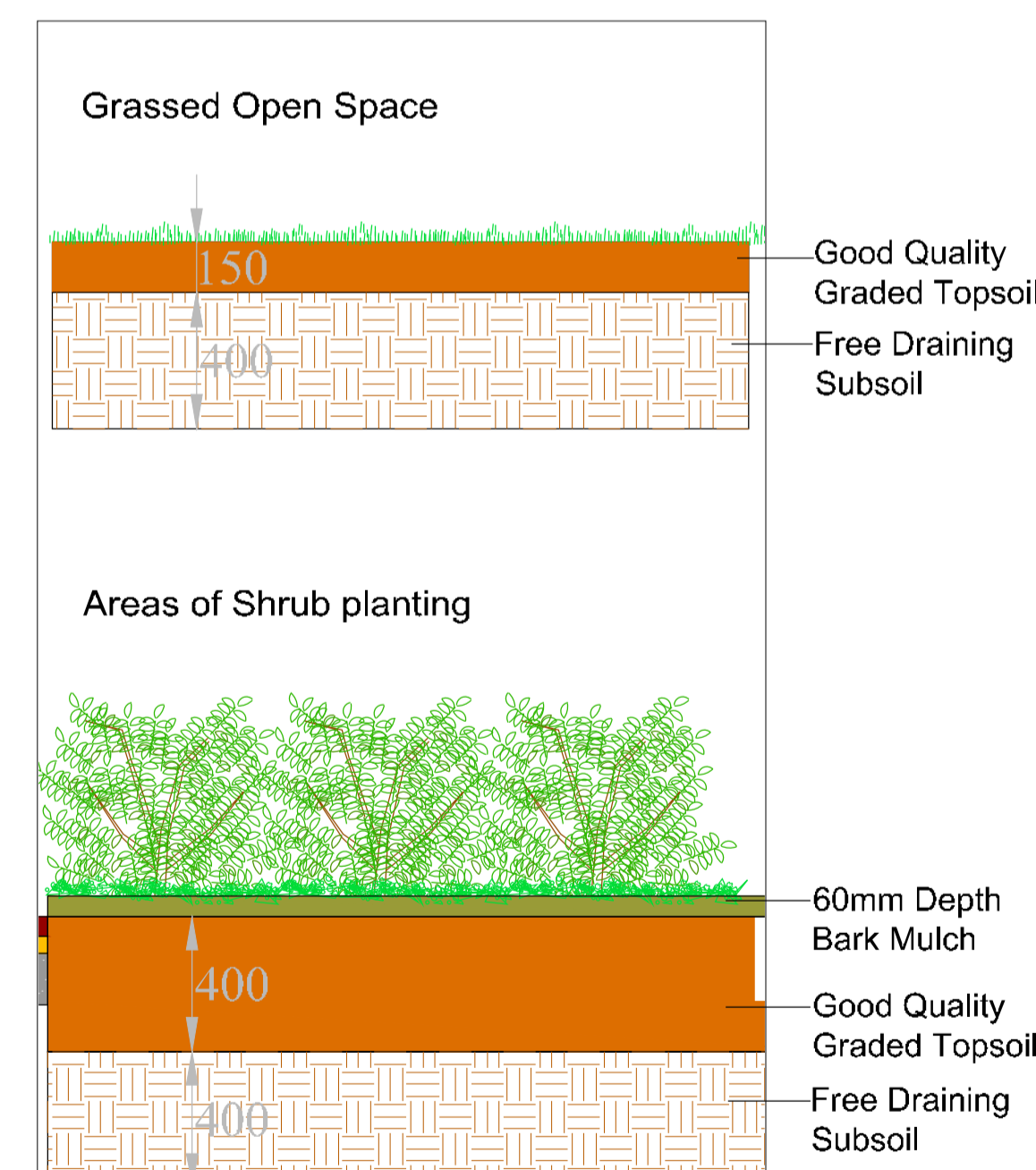

**Boundary Treatment - Scale (1:50)**

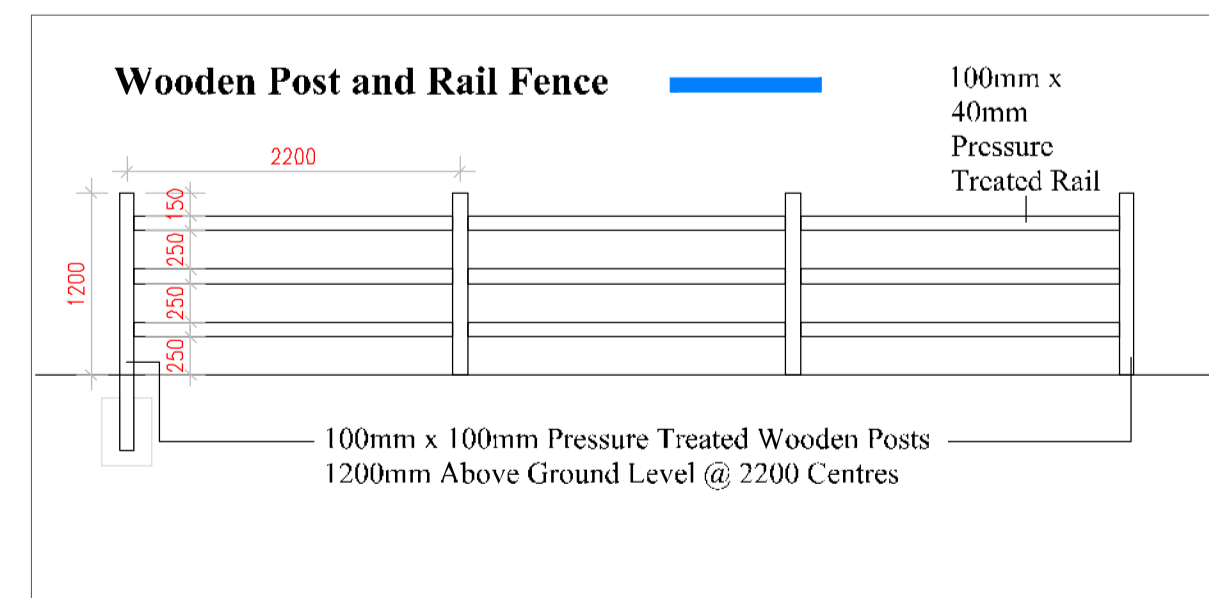

**Boundary Treatment - Scale (1:50)**

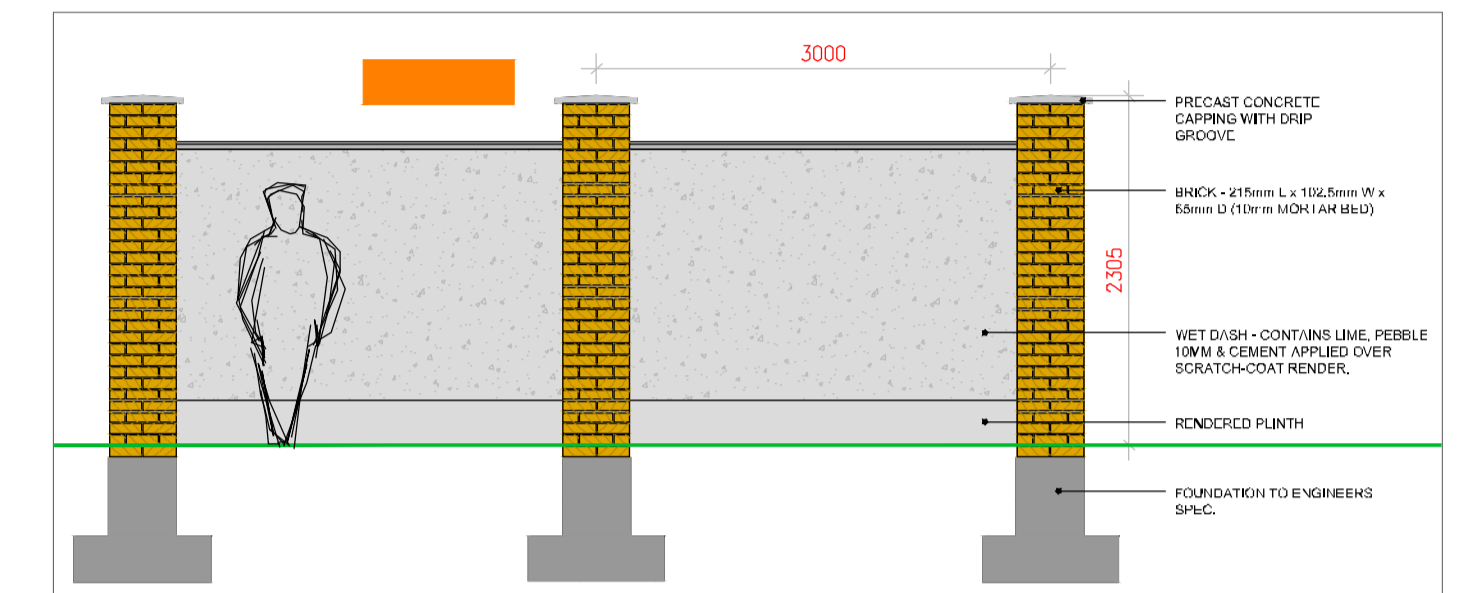

**Boundary Treatment - Scale (1:50)**

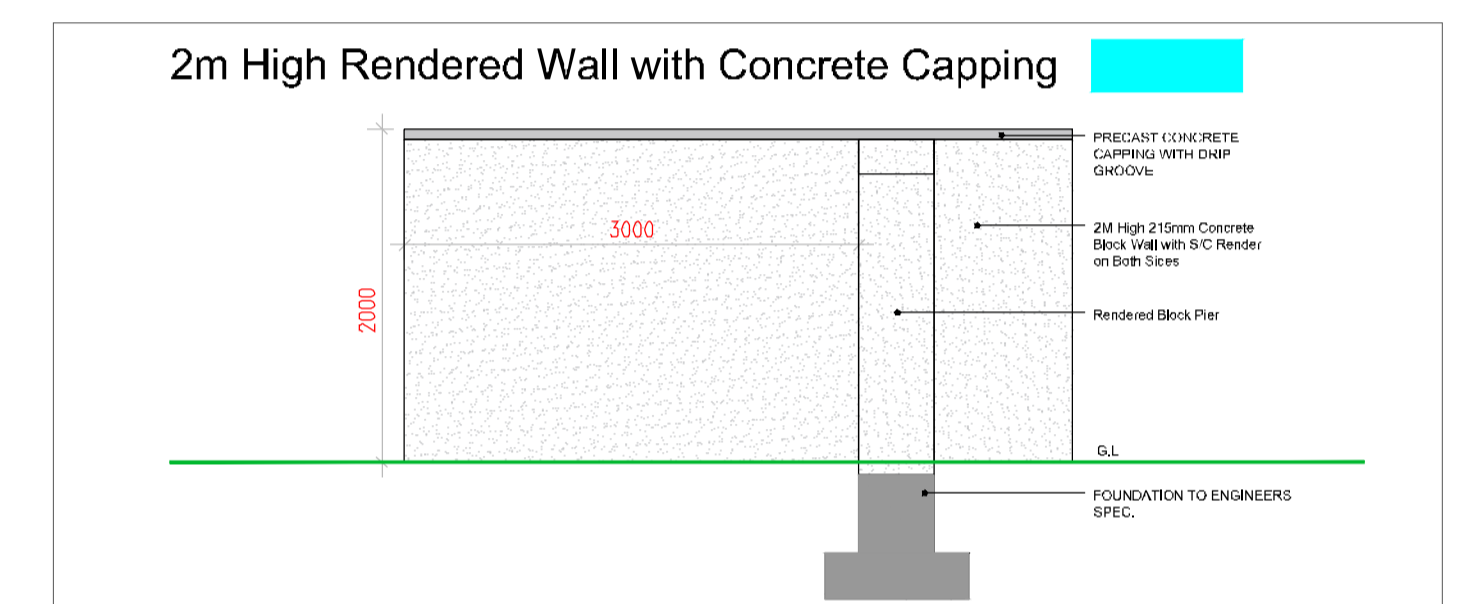

**Boundary Treatment - Scale (1:50)**

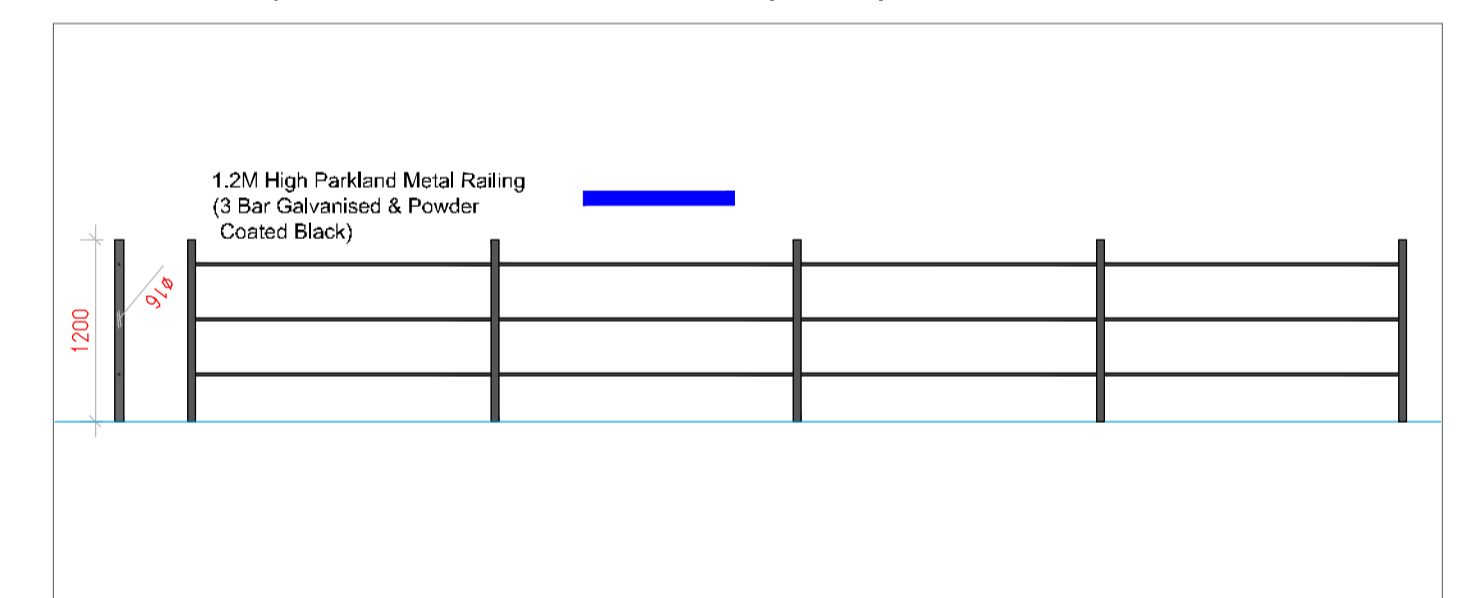

**Boundary Treatment - Scale (1:50)**

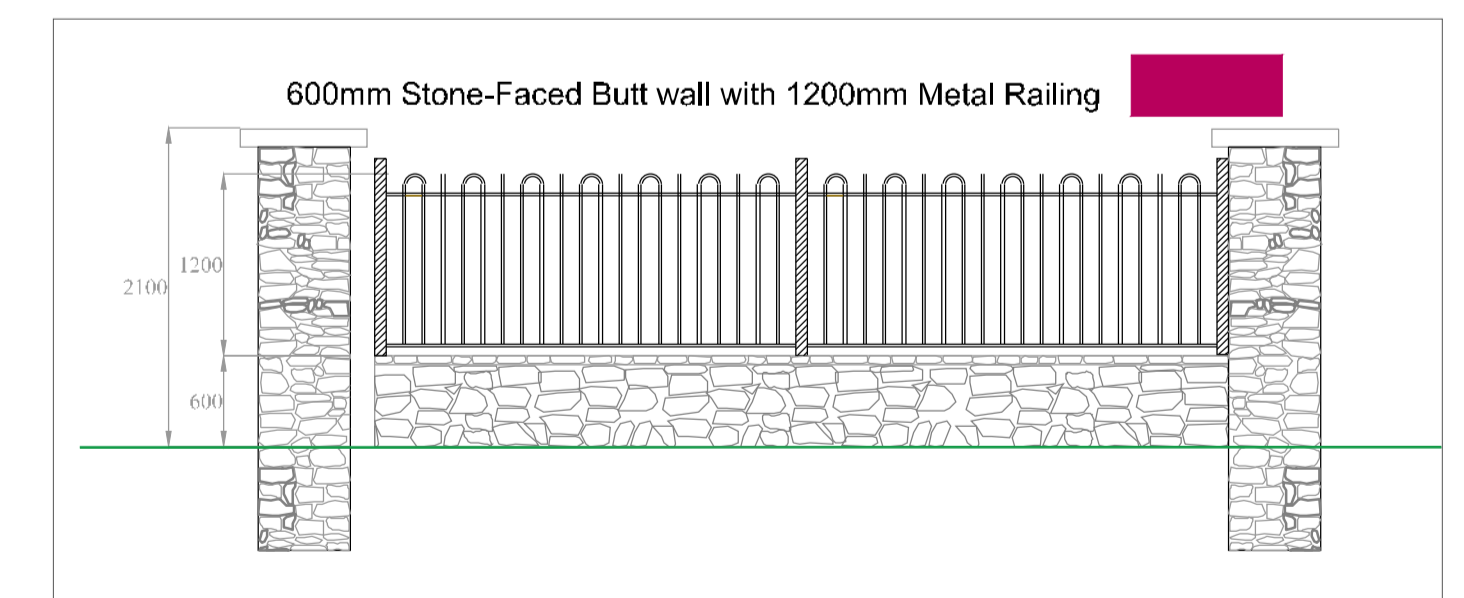

**H1 - Hedgerow Planting Detail**

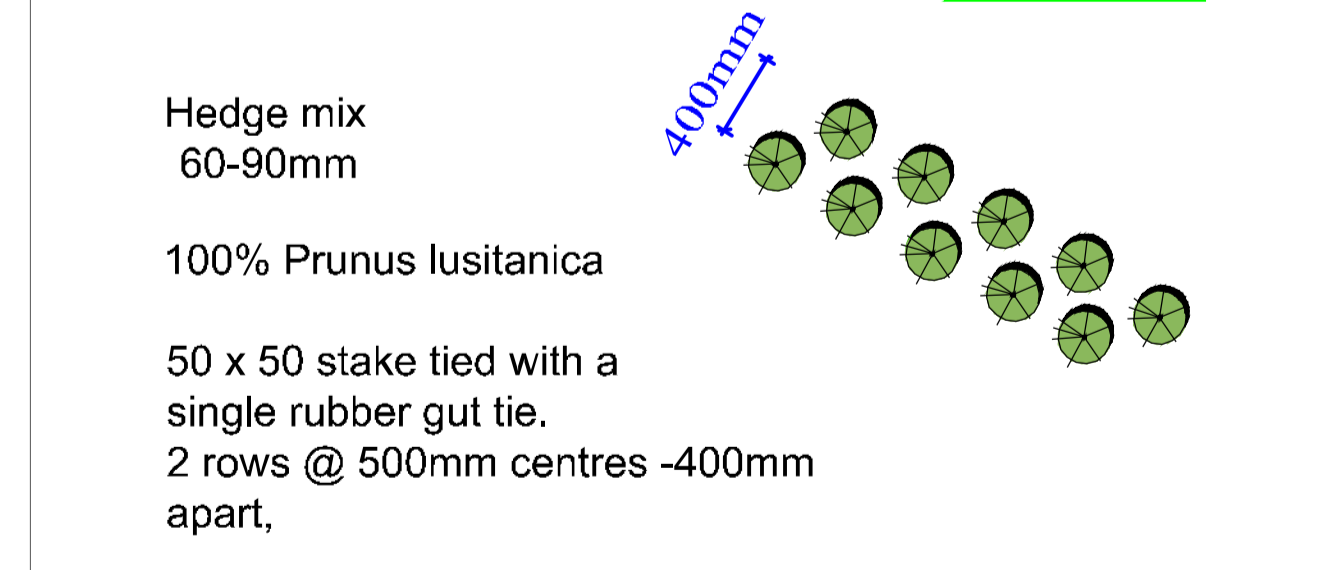

Notes:

Revisions:

REV	DATE	BY	DESCRIPTION
A	09.01.2019	MR	Revised Layout
B	16.01.2019	MR	Revised Layout

Project Title: Proposed Residential Development at Newtown, Drogheda, Co. Louth

Dwg No.: 06 (A1)

Client:

Scale: As shown - A1

Drawing Title: Landscape Spec. Sheet

Date: 28.11.2018

Job No.: 1450

Drawing By: JC

Checked By: RMD

**Ronan MacDiarmada + Associates Ltd.**  
Landscape Architects and Consultants.  
5 Tootenhill, Rathcoole, Co. Dublin  
tel: +353 1 412 4476 mob: 086 26 25 438  
fax: +353 1 401 3748 e-mail: ronan@rmcda.ie

This Drawing is Copyright